

Keston

BY IDEAL BOILERS

KESTON HEAT

45kW & 55kW Output Natural Gas & LPG

5 YEAR WARRANTY[†]

- 5 year warranty[†]
- FREE COMMISSIONING[†]
- Condensing outputs 45 & 55kW
- Inbuilt weather compensator
- Inbuilt pump (low energy modulating)
- Minimum pressure 0.3 bar
- Minimum head 3m
- Twin flue up to 21m*
- 5:1 turndown ratio
- Small installation footprint
- Low NOx Class 5
- 50mm muPVC (PVC-C) solvent weld flue allowing simple, cost effective installations**
- Commercial control system compatibility as standard
- Twin thermostat
- British Gas service listed
- ECA listed



MODULATING PUMP

Keston Heat boilers come with a low energy modulating pump which complies with energy efficiency requirements



FRAME AND HEADER KIT

Able to facilitate up to 6 Keston Heat boilers in cascade



TWIN FLUE DESIGN

Providing the perfect solution for problematic and awkward installations



WEATHER COMPENSATOR

All models in the Keston range come complete with weather compensation as standard



BRITISH BUILT SINCE 2013

All Keston boilers are built in and designed for the British market

[†] 2 year parts & labour warranty as standard. 5 year warranty available subject to being commissioned by Keston Boilers. Free Commissioning only available when a Keston 28mm System Filter is installed with a single Keston Heat boiler; not available on multiple (cascade) boiler installations. Terms and conditions apply.* For maximum total equivalent flue length please refer to the installation instructions for full details. ** The only systems approved for this application are: Marley muPVC (PVC-C) Solvent Weld Waste System (50mm), Polypipe System 2000 muPVC (PVC-C) Solvent Weld Waste System (50mm), Polypipe Terrain Solvent Weld System (50mm) and Wavin Osma PVC-C Solvent Weld System (50mm). Please use the recommended Solvent Weld Cement for each system.

SPECIFICATION DATA

CENTRAL HEATING			45	45P	55	55P
Boiler Output (Non Condensing) Mean 70°C	Max	kW	42.6	42.6	52.1	52.1
	Min	kW	12.0	12.0	12.0	12.0
Boiler Output (Condensing) Mean 40°C	Max	kW	45.0	45.0	55.0	55.0
	Min	kW	12.7	12.7	12.7	12.7
Boiler Input Net	Max	kW	43.2	43.2	52.7	52.7
	Min	kW	12.2	12.2	12.2	12.2
Boiler Input Gross	Max	kW	47.9	47.9	58.5	58.5
	Min	kW	13.5	13.5	13.5	13.5
Gas Consumption / Rate	Max	m ³ /h	4.56	1.78	5.57	2.18
	Max	ft ³ /h	161.2	62.9	196.9	76.8
Flue Gas Flow Rate	Max	m ³ /h	66.4	64.3	81.0	77.4
	Max	ft ³ /h	2,343	2,271	2,861	2,733

OTHERS			45	45P	55	55P
Efficiency	Seasonal	%	96	96	96.7	96.7
	SEDBUK 2009	%	89.2	89.2	89.6	89.6
Seasonal Space Heating Efficiency Class			A	A	A	A
NOx	Weighted	mg/kWh	38.6	43.9	38.3	59.2
		ppm DAF	21.9	24.7	21.7	33.3
	Classification		Class 5	Class 5	Class 5	Class 5
CO ₂ (±0.5)	Max	%	9.3	11	9.5	11.2
	Min	%	8.4	10.2	8.4	10.2

GENERAL DATA			45	45P	55	55P
Max Horizontal Flue Length	m		21 Flue / 2 Air	13 Flue / 1 Air	17 Flue / 2 Air	17 Flue / 1 Air
Max Horizontal Flue Length (Parallel)	m		15 Flue / 15 Air	9.5 Flue / 9.5 Air	15 Flue / 15 Air	12.25 Flue / 12.25 Air
Flue Terminal Diameter	mm		50			
Gas Supply			2H - G20 - 20mbar	3P - G20 - 37mbar	2H - G20 - 20mbar	3P - G20 - 37mbar
Gas Supply Connection			G 3/4			
Flow Connection			G 1 1/4			
Return Connection			G 1 1/4			
Max Pressure (Sealed System)	bar (psi)		6.0 (87.0)			
Maximum Static Head	m		61.0			
Electricity Supply			230V - 50Hz			
Fuse Rating	A		4.0			
Power Consumption	W		180	202	262	239
IP Rating			IP20			
Condensate Drain	mm		25			
Water Content	l		5.0			
Dry Weight	kg		60.3			

EXAMPLE FLUE INSTALLATION

Keston Heat 45 - Flue & Air Pipe Length

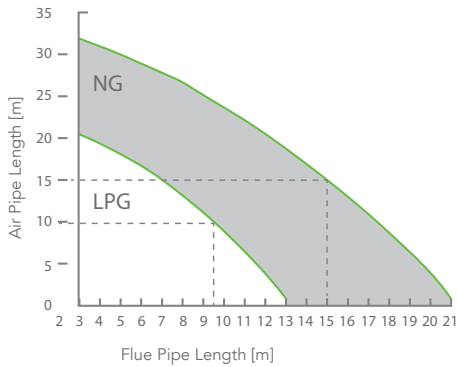

acceptable flue operating area

Graph indicates:

Natural Gas: maximum flue run 21m with 2m air. Also, 15m flue with 15m air pipe for parallel twin flue run. **LPG:** maximum flue run 13m with 1m air. Also, 9.5m flue with 9.5m air pipe for parallel twin flue run.

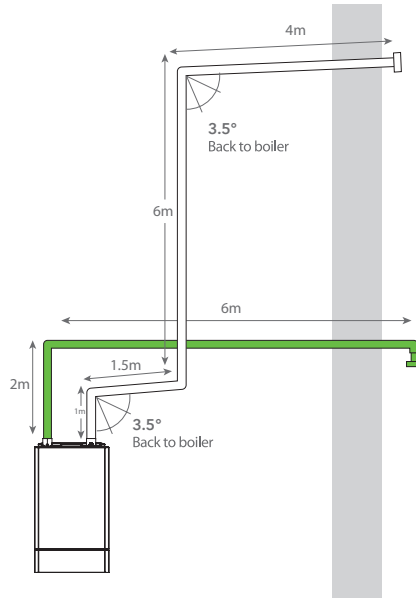

C53 HORIZONTAL

Calculations

Flue
Elbows 3 x 1m = 3m
Straights 4+6+1.5+1 = 12.5m
Total = 15m

Air
Elbows 2 x 1m = 2m
Straights 6+2+0.1m = 8.1m
Total = 10.1m

Keston Heat 55 - Flue & Air Pipe Length

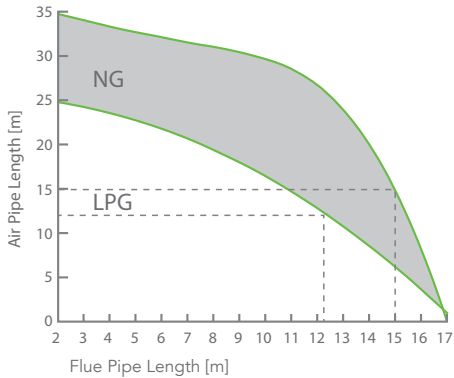

acceptable flue operating area

Graph indicates:

Natural Gas: maximum flue run 17m with 2m air. Also, 15m flue with 15m air pipe for parallel twin flue run. **LPG:** maximum flue run 17m with 1m air. Also, 12.25m flue with 12.25m air pipe for parallel twin flue run.

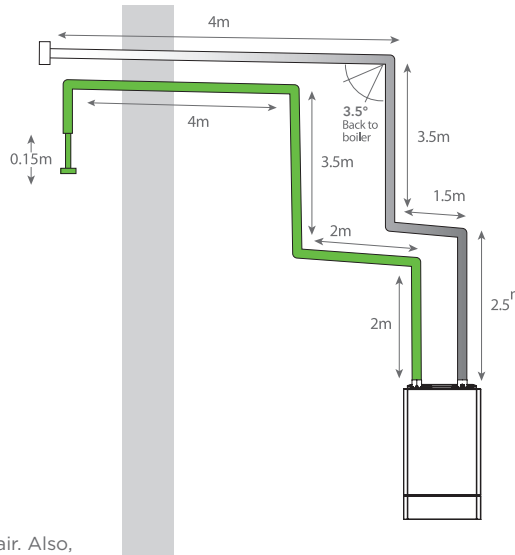

C13 HORIZONTAL

Calculations

Flue
Elbows 3 x 1m = 3m
Straights 2.5+1.5+3.5+4 = 11.5m
Total = 14.5m

Air
Elbows 4 x 1m = 4m
Straights 2+2+3.5+4+0.15 = 11.65m
Total = 15.65m

DIMENSIONS

KESTON HEAT

Height 850mm

Width 500mm

Depth 360mm

The following minimum clearances must be maintained for operation and servicing.

Front of boiler - 450mm*

Sides of boiler - 25mm

Above boiler - 350mm, with 30mm above the flue

Below boiler - 300mm

Clearance between multiple boiler installations - 25mm

* Can be reduced to 5mm for cupboard fit, 450mm required for servicing.